

TECH DATA SHEET

Frontier LTSeries Liner Top Packer

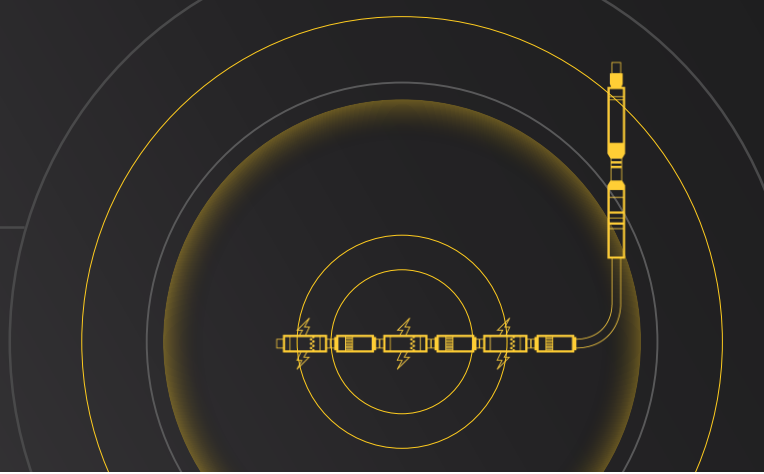

OVERVIEW

The LTSeries Liner Top Packer is a compression set Liner Top Packer, which has multiple TBR lengths available to allow for Floating Tie Back Seal Assembly to accommodate tubing movement during Frac or Production. The Packer utilizes hold-down Slip to keep Packer Anchored. Constrained Slips also allow for rotation while running the liner downhole and are held firmly to the cone preventing slip damage.

FEATURES

- Compression Set
- Rotational while being Deployed
- Slip are not set until the Element is Fully Packed Off
- Setting Sleeve Prevents Prematurely Setting
- Full ID Mandrel
- High Burst And Collapse Pressure Rating
- Element Protected with Metal to Metal Extrusion Rings
- 7,500 PSI Differential Pressure Rating
- Element Compounds available from 275F to 400F Temperature Rating Available

APPLICATIONS

- Used with Hydraulic or Mechanical Liner Hanger
- Prevents Gas Migration Liner & Casing
- Gives a Secondary Seal to Cement

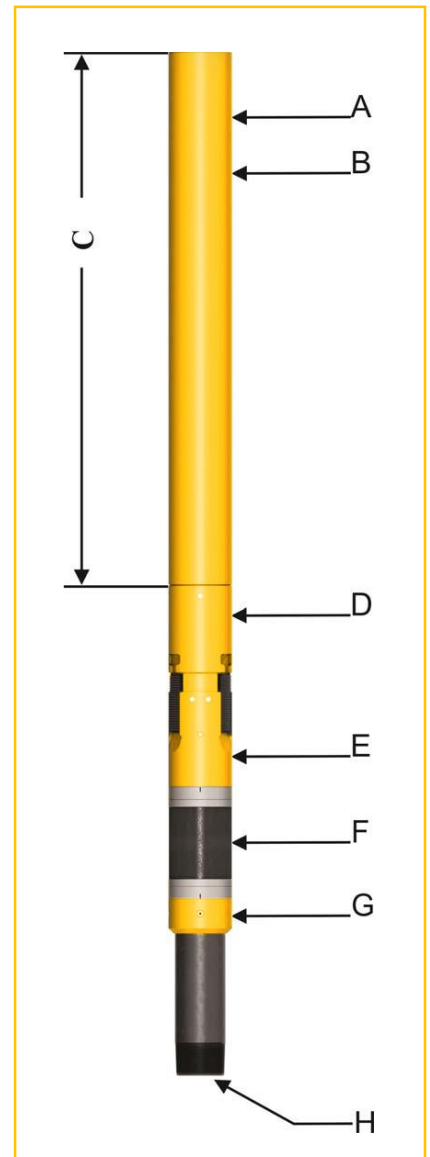

Specification

Basic Information	
Liner Size & Weight	8-5/8" 32#
Casing Size & Weight	10-3/4" 45.5 - 51#
Packer Grade	API Q-125
Element Rating	7,500 psi
Temp Rating **	275F - 400F
Thread	Metal to Metal

** Depending on Elastomer Compound

Dimensional Information 8-5/8" x 10-3/4"	
A	9.625"
B	8.750"
C **	10ft
D	9.625"
E	9.625"
F	9.594"
G	9.625"
H	7.921"

** Other Lengths Available on Request

Mechanical Specifications 8-5/8" x 10-3/4"	
Tensile (lbs)	727,490
Body Burst (psi)	8,804
Body Collapse (psi)	8,225
Tieback Collapse (psi)	11,878
Tieback Burst (psi)	10,847
Tensile (lbs)	727,490

* Or by Thread

