

**TECH DATA SHEET**

# Frontier LTSeries Liner Top Packer

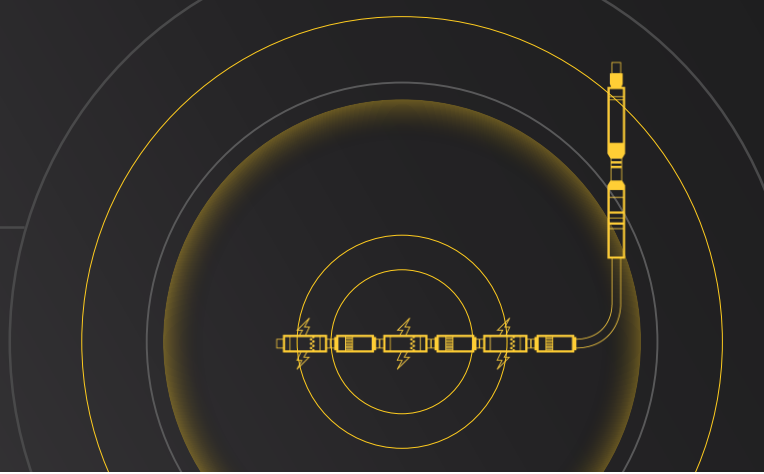

## OVERVIEW

The LTSeries Liner Top Packer is a compression set Liner Top Packer, which has multiple TBR lengths available to allow for Floating Tie Back Seal Assembly to accommodate tubing movement during Frac or Production. The Packer utilizes hold-down Slip to keep Packer Anchored. Constrained Slips also allow for rotation while running the liner downhole and are held firmly to the cone preventing slip damage.

## FEATURES

- Compression Set
- Rotational while being Deployed
- Slip are not set until the Element is Fully Packed Off
- Setting Sleeve Prevents Prematurely Setting
- Full ID Mandrel
- High Burst And Collapse Pressure Rating
- Element Protected with Metal to Metal Extrusion Rings
- 7,500 PSI Differential Pressure Rating
- Element Compounds available from 275F to 400F Temperature Rating Available

## APPLICATIONS

- Used with Hydraulic or Mechanical Liner Hanger
- Prevents Gas Migration Liner & Casing
- Gives a Secondary Seal to Cement

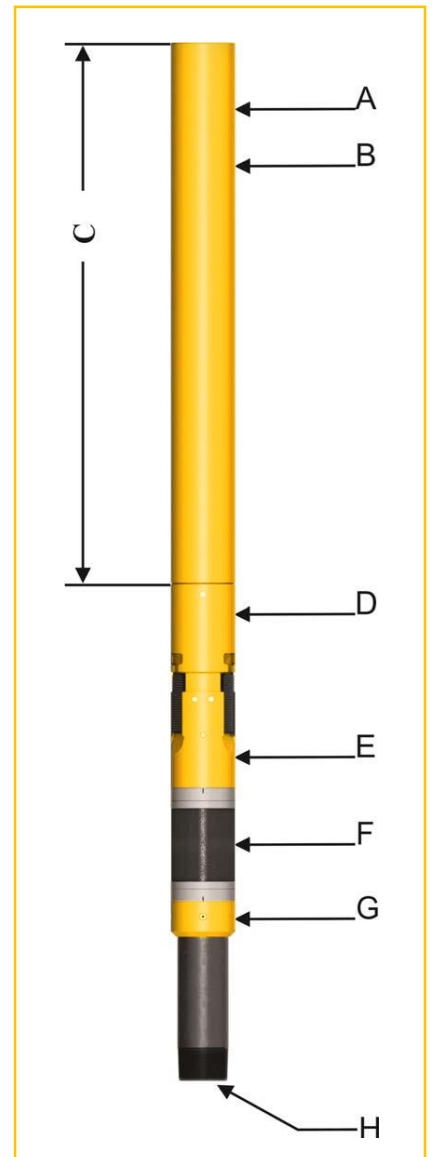

## Specification

Basic Information	
Liner Size & Weight	7-5/8"
Casing Size & Weight	9-5/8 x 43.5 - 47#
Packer Grade	API Q-125
Element Rating	10,000 psi
Temp Rating **	275F - 400F
Thread	Metal to Metal

\*\* Depending on Elastomer Compound

Dimensional Information 7-5/8" x 9-5/8"	
A	8.375"
B	7.750"
C **	10ft
D	8.375"
E	8.375"
F	8.313"
G	8.375"
H	6.765"

\*\* Other Lengths Available on Request

Mechanical Specifications 7-5/8" x 9-5/8"	
Tensile (lbs)	641,587
Body Burst (psi)	12,847
Body Collapse (psi)	11,650
Tieback Collapse (psi)	9,675
Tieback Burst (psi)	8,980
Tensile (lbs)	641,587

\* Or by Thread

